

FUEL FLOW INDICATING - MAINTENANCE PRACTICES (PT6A-114/PT6A-114A)

1. General

- A. This section gives the removal and installation procedures for the fuel flow indicator for Airplanes 20800001 thru 20800500 and Airplanes 208B0001 thru 208B1999. For Airplanes 20800500 and On and Airplanes 208B2000 and On the fuel flow indication is show on the Garmin G1000 Multifunction Display (MFD).
- B. This section gives the removal and installation procedures for the fuel flow transmitter for Airplanes 20800001 and On and Airplanes 208B0001 thru 208B2196 and 208B2198 thru 208B4999. For the fuel flow transmitter removal and installation procedures for Airplane 208B2197 and Airplanes 208B5000 and On refer to Fuel Flow Transmitter - Removal/Installation (PT6A-140).
- C. This section gives the installation procedures for conical seals in the fuel transmitter line.

2. Description and Operation

- A. The fuel flow indicating system measures rates of flow by means of an inline transmitter, which provides an electrical signal, and a fuel flow indicator, which displays the fuel flow information.

3. Fuel Flow Indicator Removal/Installation

CAUTION: Handle fuel flow indicator with care during removal/installation to prevent damage to indicator.

- A. Remove Fuel Flow Indicator (Refer to Figure 201).
 - (1) Turn all electrical power OFF.
 - (2) Loosen screw (2) only.
 - (3) Slide fuel flow indicator (1) aft, out of instrument panel.
 - (4) Disconnect electrical connector (3).
 - (5) Remove fuel flow indicator (1).
- B. Install Fuel Flow Indicator (Refer to Figure 201).
 - (1) Position fuel flow indicator (1) in instrument panel.
 - (2) Connect electrical connector (3) to fuel flow indicator (1).
 - (3) Position fuel flow indicator (1) in instrument panel and tighten screw (2).

4. Fuel Flow Transmitter Removal/Installation

CAUTION: Handle fuel flow transmitter with care during removal/installation to prevent damage to transmitter.

- A. Remove Fuel Flow Transmitter (Refer to Figure 201, Sheet 2).
 - (1) Turn all electrical power OFF.
 - (2) Open upper right cowling door to gain access to fuel flow transmitter (2).
 - (3) Disconnect electrical connector (5) at fuel flow transmitter (2).
 - (4) Remove safety wires (1) and fuel lines (3) and (4).
 - (5) Remove fuel flow transmitter (2).

NOTE: Cap all open fuel lines and fittings.

- B. Install Fuel Flow Transmitter (Refer to Figure 201, Sheet 2).
 - (1) Position fuel flow transmitter (2) between fuel lines (3) and (4).

CAUTION: Ensure arrow on fuel flow transmitter is pointing in proper direction. Arrow should indicate direction of flow from pump to flow divider.

- (2) Remove caps and connect fuel lines (3) and (4).
- (3) Safety wire fuel lines (3) and (4) to fuel flow transmitter (2).
- (4) Connect electrical connector (5) to fuel flow transmitter (2).
- (5) Close cowling door.
- (6) Perform engine operational check. Refer to Pilot's Operating Handbook and FAA Approved Airplane Flight Manual.

5. Conical Seal Installation (Fuel Transmitter Line Assembly Leakage)

CAUTION: Do not install seal into line assembly. Seal shall be installed on male fitting only. Do not lubricate the

seal or threads.

NOTE: Conical seals are allowed only at the fuel transmitter line connections and are only to be used if the cause of the leak is a damaged male fitting (slight deformation) of the fuel transmitter. Any leakage caused by other damage, such as cracked fittings or deformed line assembly flares, cannot be corrected with conical seals, but must be corrected by replacement of the torque transducer and/or line assemblies.

A. Installation of Conical Seal (Refer to Figure 201, Sheet 2).

- (1) Disconnect airplane battery.
- (2) Remove safety wire (1) from fittings.
- (3) Disconnect fuel lines (3) and (4).
- (4) Inspect line flares and fuel transmitter fittings for cracks or deformities. If cracks or deformities are found, replace lines/transmitter as required.
- (5) If lines or transmitter are replaced connect lines and check for leaks in accordance with step (10). If no leak is found, it will not be necessary to install conical seals.
- (6) If leak is found install conical seal onto male flare portion of fitting. The flats on conical seals are designed to provide proper positioning of seal onto the male fitting to prevent cocking of the seal that could cause flow restriction.
- (7) Thread line assembly nut onto the male flared fitting several turns with fingers until joint is snug. If line assembly nut cannot be tightened snugly with finger torque, disassemble and correct problem to prevent damage to conical seal.
- (8) Conical seals are subject to cold creep, therefore, a double tightening procedure is required. Tighten line assembly nuts from 575 to 625 inch-pounds. Torque values are higher than torque values for lines assembly nuts without conical seals installed. Allow 5 minutes elapsed time for cold creep to occur and then recheck torque after 30 minutes, and retighten if required.
- (9) Safety wire fittings.
- (10) Check for leaks by running the engine momentarily to full power to confirm that operation is normal, and that no leakage is evident upon making a post shutdown inspection.

Figure 201 : Sheet 1 : Fuel Flow Indicator Installation

A21752

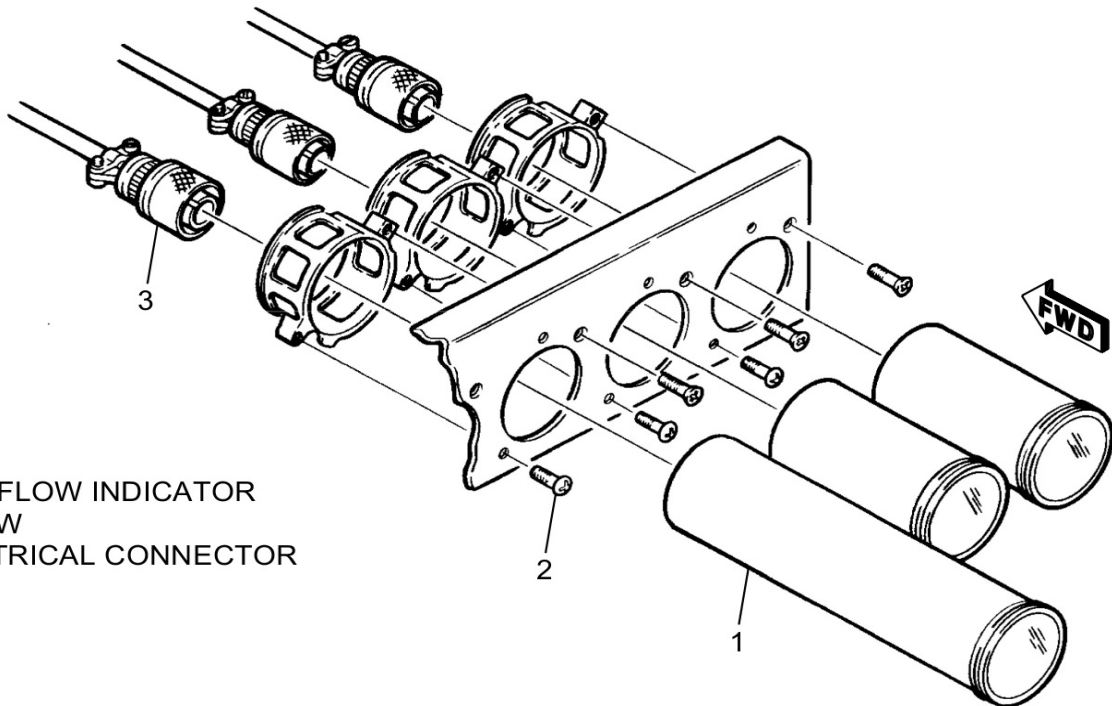
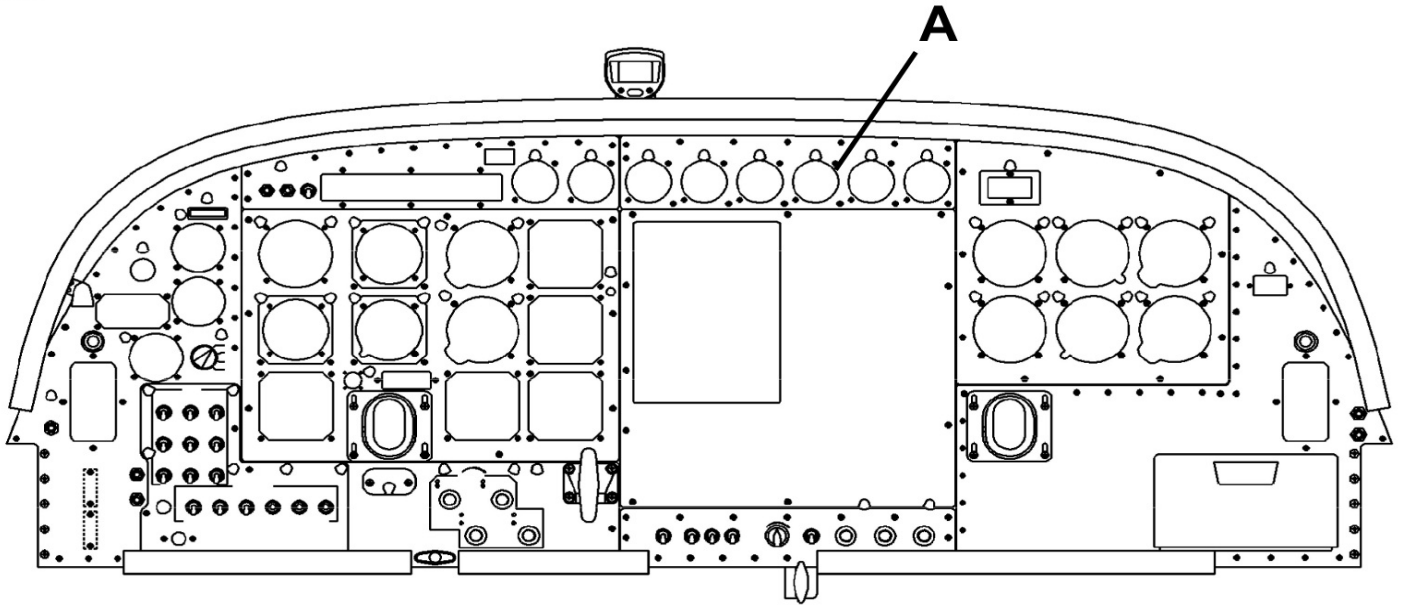

- 1. FUEL FLOW INDICATOR
- 2. SCREW
- 3. ELECTRICAL CONNECTOR

DETAIL A

AIRPLANES 20800001 THRU 20800500 AND
AIRPLANES 208B0001 THRU 208B1999

2618R1015
A2656R1023

Figure 201 : Sheet 2 : Fuel Flow Indicator Installation

A21753

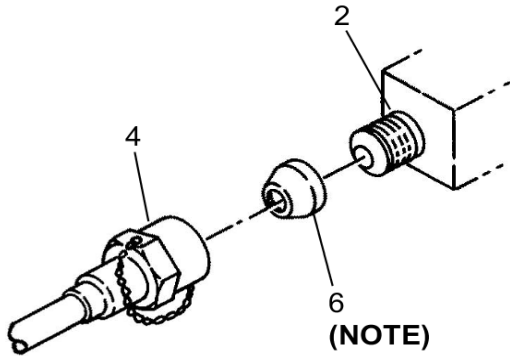

DETAIL A

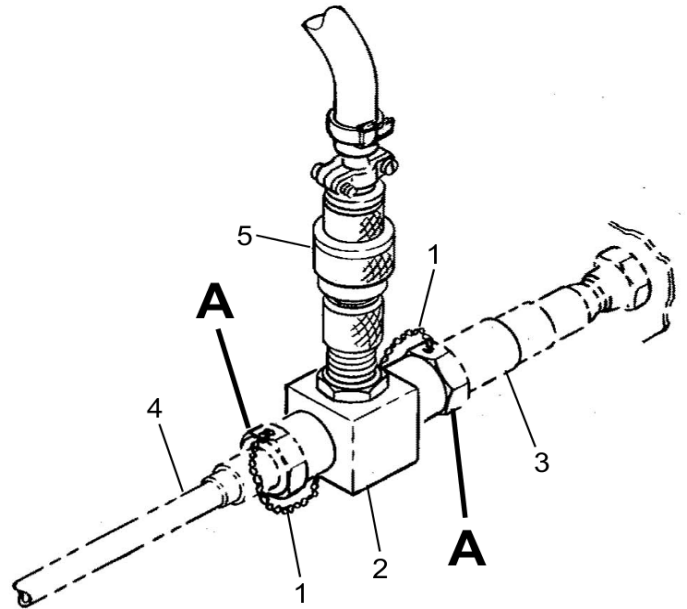

AIRPLANES 20800001 THRU 20800079

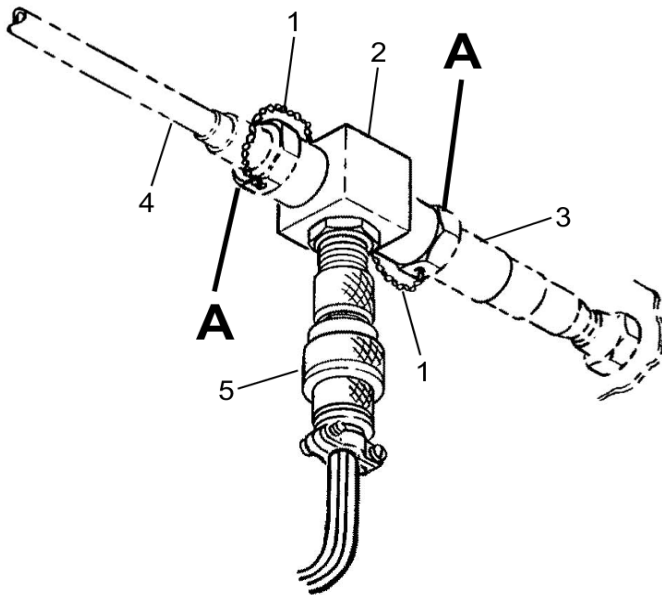

AIRPLANES 20800080 AND ON AND
AIRPLANES 208B0001 THRU 208B2196 AND
AIRPLANES 208B2198 THRU 208B4999

- 1. SAFETY WIRE
- 2. FUEL FLOW TRANSMITTER
- 3. FUEL LINE
- 4. FUEL LINE
- 5. ELECTRICAL CONNECTOR
- 6. CONICAL SEALING WASHER(NOTE)

NOTE: CONICAL SEALS ARE ALLOWED ONLY AT THE TRANSMITTER CONNECTIONS AND ARE ONLY TO BE USED IF THE CAUSE OF THE LEAK IS A DAMAGED (SLIGHTLY DEFORMED) MALE FITTING ON THE TRANSMITTER LINE.

2656R1006
2656R1024
A2656R1008